

Maintenance and Service Manual

Wheelchair-Accessible Lowered Floor Conversion (Foldout Ramp) featuring 2011 and Newer **Chrysler Minivans**

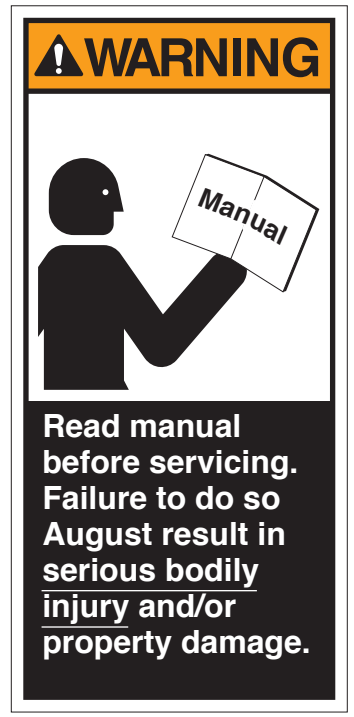

Because Life is a Moving Experience®



INTRODUCTION

Introduction

Braun lowered floor conversions are designed to provide years of pleasure and mobility independence. Familiarity with proper operation and maintenance procedures will help ensure safe, troublefree operation.

Safety precautions, maintenance and troubleshooting details are provided. Wiring Diagrams are provided to aid in troubleshooting. A Repair Parts section with exploded views and corresponding parts lists is also provided.

Refer to the information applicable for the conversion you are servicing and disregard the information that does not apply.

Warranty and Return Authorization

Refer to the Limited Warranty Booklet for detailed terms and provisions. When processing any war-

ranty claims (parts, repairs, etc.), all requests must be processed through the Braun Corporation Product Support Department. Product Support will issue a Return Material Authorization (RMA) number and detail the procedures required for processing returns and/or authorizing credit.

⚠ WARNING

Maintenance, lubrication, troubleshooting and service procedures must be performed as specified by an authorized service technician. Failure to do so may result in serious bodily injury and/or property damage.

The last eight digits of the vehicle identification number (VIN) must be provided when filing a warranty claim or ordering parts.

Operation Quick Reference Guide

Conversion Operation Overview

This overview provides a simplified explanation of operation. Read the entire owner's (operator's) manual for complete details. Contact The Braun Corporation at 1-800-THE LIFT® if any of this information is not understood.

Power Operation

Power functions are managed by the electronic control system. The control system can be activated using the OEM remote keyless entry transmitter or one of the interior control switches detailed in the operators manual.



OEM Remote Keyless Entry Transmitter

Press and release this switch two times (*2)



Interior mounted control switches display one of these graphics.



One-Touch Control Activation

Conversion power door, kneel and ramp functions are activated by pressing and releasing a control switch (press and release remote entry transmitter button twice).

Open Functions: When activating the Open functions, the power door opens, the kneel system lowers the rear of the vehicle and the ramp deploys.

Close Functions: When activating the Close functions, the ramp stows, the kneel system raises the rear of the vehicle and the power door closes.

Manual Operation

The passenger power sliding door and ramp can be manually operated. Read the owners manual for further details.

Safety Precautions	2	Repair Parts	
Towing	2	Foldout Ramp - Platform Assembly	19B, 20B, 21
Maintenance and Service Requirements	3	Foldout Ramp - Gear, Motor and Base Assembly	22, 23A, 24A
Maintenance and Lubrication Schedule	4-6	Foldout Ramp Assembly	23B, 24B, 25
Troubleshooting Diagnosis Chart	7-10	Kneel Assembly	26, 27
Microswitches	11	Dimensions	28
Below Floor Obstructions	12		
Auxiliary Power Supply	13		
Electronic Control Modules	14		
Switch and Component Location	15A, 16A		
Wiring Diagrams			
Wiring Diagram - Power Door, Foldout Ramp and Kneel System	15B, 16B		
Wiring Diagram - Front Driver Seat without Memory Seat	17A, 18A		
Wiring Diagram - Front Driver Seat with Memory Seat	17B, 18B		
Wiring Diagram - Front Passenger Seat	19A, 20A		

SAFETY PRECAUTIONS

Safety Precautions

⚠ WARNING

Read this manual, the conversion's operator's manual and supplements before performing operation, maintenance or service procedures. Failure to do so may result in serious bodily injury and/or property damage.

- ⚠ WARNING** Maintenance and service procedures must be performed only by authorized service personnel.
- ⚠ WARNING** Perform maintenance and lubrication procedures exactly as outlined in the Maintenance and Lubrication Schedule contained in this manual.
- ⚠ WARNING** Perform troubleshooting and service procedures as outlined in this manual and/or service bulletins supplied with replacement parts.
- ⚠ WARNING** Replacement parts must be Braun authorized replacements.
- ⚠ WARNING** Do not attempt to interface aftermarket control systems without authorization from The Braun Corporation.

- ⚠ WARNING** Do not use accessory devices not authorized by The Braun Corporation.
- ⚠ WARNING** Keep clear of area in which the vehicle kneels (lowers).
- ⚠ WARNING** Keep clear of area in which ramp operates.
- ⚠ WARNING** Never modify (alter) a Braun Corporation lowered floor minivan conversion.
- ⚠ WARNING** Do not install a raised top on a Braun Corporation lowered floor minivan conversion.
- ⚠ WARNING** Use of a Braun Corporation lowered floor minivan conversion for towing is prohibited.
- ⚠ WARNING** Failure to follow these safety precautions may result in serious bodily injury and/or property damage.

Towing

Towing with a Lowered Floor Conversion

Use of a lowered floor conversion vehicle for towing is prohibited.

Transporting a Lowered Floor Conversion

If case of service, The Braun Corporation recommends that lowered floor conversion vehicles be transported on a trailer rather than towed with one set of wheels suspended and the other set of wheels remaining in road contact.



Trailer Transport

Maintenance and Service Requirements

Braun lowered floor minivan conversions must be maintained and serviced by a Braun authorized service representative who has attended and been certified by The Braun Corporation Sales and Service School for Braun Mobility Products.

Read and become familiar with the operating procedures outlined in the applicable operator's manual and the maintenance and troubleshooting information contained in this manual before beginning operation, maintenance or service procedures. Contact The Braun Corporation at 1-800-THE LIFT® if any of this information is not understood.

Electronic Control System:

The electronic control system provides simple one-touch activation of power functions. For your convenience, the control system can be activated using the OEM remote keyless entry transmitter or one of the interior switches identified in the operator's manual.

Braun Corporation Aftermarket Control Systems Policy:

The Braun Corporation manufactures dedicated control systems for its products. These control systems have been designed and tested for use in conjunction with specific Braun products. Braun control systems are the only control systems authorized for use with Braun products.

Do not attempt to interface aftermarket control systems without authorization from The Braun Corporation. To do so may result in serious bodily injury and/or property damage.

MAINTENANCE and SERVICE

Preventive Maintenance

Maintenance is necessary to ensure safe and trouble free conversion operation. Encourage the consumer to perform preventive maintenance procedures. General preventive maintenance consisting of inspections along with cleaning procedures should be a part of the consumers routine.

Keeping the passenger slide door lower track pan free of debris, ice and snow is one of the most effective preventive maintenance practices to exercise. Regular preventive maintenance procedures will increase the service life of the conversion, as well as enhancing safety.

The consumer should inspect and clean frequently and routinely (minimum four weeks or 100 cycle intervals).

Note: A Preventive Maintenance section is provided in the operator's manual.

Maintenance and Lubrication Schedule

Normal vehicle maintenance must be performed as outlined in the OEM-supplied owner's manual. This maintenance is not the responsibility of The Braun Corporation.

The maintenance and lubrication procedures outlined in this schedule must be performed at the recommended scheduled intervals by a Braun authorized service representative.

Clean specified components and the surrounding area before applying lubricants. When replacing lubricated components, be sure to lubricate during installation procedures.

A "dri-film" style of light oil should be applied where Light Oil is called out (goes on wet and then dries). Lubricants of this type are available that do not attract dust and other debris.

Use of improper lubricants can attract dirt or other contaminants which could result in wear or damage to components. Avoid lubricants that can leave stains.

Some lubricants referenced in the schedule are available from The Braun Corporation (part numbers provided where specified).

Inspection, lubrication and maintenance procedures should be repeated at 3 month intervals following the scheduled 6 month maintenance. These intervals are a general guideline and will vary according to frequency of use and conditions. Exposure to severe conditions (weather, environment, contamination, heavy usage, etc.) may require inspection and maintenance procedures to be performed more often than specified.

Discontinue use immediately if maintenance and lubrication procedures are not properly performed, or if there is any sign of wear, damage, improper operation or any abnormal condition. Contact your sales representative or call The Braun Corporation at 1-800-THE LIFT®. One of our national Product Support representatives will direct you to an authorized service technician who will inspect your conversion.

WARNING

Maintenance and lubrication procedures must be performed as specified by an authorized service technician. Failure to do so may result in serious bodily injury and/or property damage.

Maintenance and Lubrication Schedule

3 Months	<p>Foldout Ramp: Foldout ramps vary in design. Disregard references to components not present.</p>	
	Outboard ramp extension hinge and fasteners	Clean and lubricate with Light Oil. Resecure or replace fasteners as needed
	Inspect ramp inboard pivot points (bolts/screws and bushings/bearings) for positive securement, wear or damage	Clean and lubricate with Light Oil. Tighten, replace or correct as needed
	Inspect ramp fold pickup bearing for positive securement, alignment, wear or other damage	Replace or correct as needed. If bearing retaining screw is not secure or is removed for service, apply Blue #242 Thread Locker Loctite to retaining screw and tighten.
	Inspect ramp fold arm for positive securement, alignment, wear or other damage	Tighten, replace or correct as needed
	Inspect ramp fold arm bearing slot for excessive wear or damage	Replace if needed
	Inspect ramp extension chain for proper alignment, securement or other defects	Realign, resecure, replace or otherwise correct as needed
	Inspect ramp floor mounting hardware for securement (loose or missing)	Resecure, replace or correct as needed
	General Items	
	Lower power slide door track	Inspect for obstructions and clean (vacuum or blow out debris using compressor)
Wheelchair and occupant restraint belts and tie down track	Inspect for any defects such as cuts, fraying or any malfunction of belt, buckle or securement hardware. Clean dirt and debris from tie down track. Replace immediately if damaged.	
Inspect removable seat bases for proper engagement of latching mechanisms	Replace or correct as needed	

MAINTENANCE and SERVICE

Maintenance and Lubrication Schedule

6 Months	Perform all procedures listed in previous section also	
	<p>Power Fold Ramps:</p> <ul style="list-style-type: none"> • Ramp flap (extension) chain 	Lubricate with Anti-Seize (14 oz. caulk tube available per Braun part no. 24710)
	<p>Remove ramp housing cover/rear vertical panel and inspect:</p> <ul style="list-style-type: none"> • Top mount bracket bolts for securement (loose or missing) • Motor mounting bolts for securement (loose or missing) • Ramp fold arm securement (collar and mounting screws) • Microswitches securement and adjustment • Microswitch wires and terminals for securement or damage • Magnetic switch (optional) 	Resecure, adjust microswitches (page 11), replace damaged parts or otherwise correct as needed. See Ramp Exploded views on pages 19B-20B, 23A-24A and 23B-24B.
	<p>Inspect power source: Vehicle battery, 50 ampere fuse, vehicle engine compartment fuse block and driver side under dash-mounted fuse block.</p>	Resecure, repair or replace
	<p>Inspect kneel actuator assembly for:</p> <ul style="list-style-type: none"> • Actuator mounting pin securement (micro-switch activation block) • Inspect chain for misalignment, wear or damage • Inspect chain master-links for securement • Inspect chain roller for securement, wear, damage or misalignment • Inspect electrical harnesses for positive connections, proper routing, wear or other damage • Kneel microswitch(es) securement, wear or other damage 	Realign, resecure, replace damaged parts or otherwise correct as needed. See Kneel Assembly exploded view on page 27.
	<p>Kneel electrical override</p> <p>Kneel assembly chain</p>	<p>Check operation</p> <p>Lubricate with Anti-Seize (14 oz. caulk tube available per Braun part no. 24710)</p>

Consecutive 3 Month Intervals	Repeat all previously listed inspection, lubrication and maintenance procedures at 3 month intervals.
--------------------------------------	---

Troubleshooting Diagnosis Chart

⚠ WARNING

Troubleshooting and repair procedures must be performed as specified by an authorized service technician only. Failure to do so may result in serious bodily injury and/or property damage.

Operation should be discontinued immediately if a conversion problem occurs. Repairs should not be attempted by the consumer. Contact the sales representative or call The Braun Corporation at 1-800-THE LIFT®. One of our national Product Support representatives will direct you to an authorized service technician who will inspect your vehicle.

The cause of the problem can be determined by locating the function and related symptom in the Troubleshooting Diagnosis

Charts. The specific cause and remedy can then be determined by process of elimination. Wiring Diagrams are provided to aid in troubleshooting.

A Repair Parts section with exploded views and corresponding parts lists is also provided. Correct the problem if possible. If the problem continues, contact The Braun Corporation.

FUNCTION	SYMPTOM	POSSIBLE CAUSE	REMEDY
1.00 NO OPERATION	1.10 No Power to Conversion Systems (Circuit Problem)	1.11 Poor ground connection 1.12 Battery terminals dirty 1.13 Battery damaged 1.14 Battery discharged 1.15 12 volt source (check fuses for 12 volts) 1.16 Circuit breaker tripped or damaged	Clean and tighten Clean and tighten Replace Charge battery Check for blown fuse, loose terminals or broken wire or cable Reset or replace
	1.20 Power to Conversion Systems But No Operation	1.21 Transmission not in Park 1.22 Chrysler Slide Door Master Lock Out switch in OFF position 1.23 Slide door handles have been manually operated 1.24 Loose connection 1.25 Broken wire 1.26 Wire terminal 1.27 Control switch damaged 1.28 OEM keyless transmitter (FOB) does not function properly or damaged 1.29 Braun electronic controller	Engage transmission in Park Press switch to ON position Press a control switch Clean and tighten Repair or replace Crimp tightly to wire Replace Relocate to avoid interference, replace battery or replace transmitter. See OEM owner's manual. Press main electronic controller reset button and try operation again. If no operation - run serial diagnostics test. If no operation - contact Braun Product Support.

TROUBLESHOOTING

FUNCTION	SYMPTOM	POSSIBLE CAUSE	REMEDY
2.00 KNEEL SYSTEM (LOWER)	2.10 No Lower Operation	2.11 See 1.00 2.12 Kneel On/Off switch is in OFF position. 2.13 Actuator harness disconnected or otherwise damaged 2.14 Actuator damaged. Note: Actuator can be checked with kneel override switch (under driver side third row seat). 2.15 Chain disconnected or otherwise damaged 2.16 Kneel Lowered microswitch harness disconnected/damaged or microswitch damaged 2.17 Kneel electrical override switch damaged or disconnected	Press switch to ON position Connect, repair or replace Press the kneel electrical override switch to test actuator (driver side third row seat). Replace if damaged. Connect, repair or replace Connect/repair harness or replace microswitch Check connection or replace
	2.20 Faulty Kneel (Lower) Operation	2.21 Mechanical binding 2.22 Misalignment or damage to kneel system components. Inspect kneel actuator assembly for: <ul style="list-style-type: none"> • Actuator mounting pin securement (loose or missing) • Inspect chain for wear, misalignment, or other damage • Inspect chain pulley for securement, wear, misalignment or damage 	Check and correct Connect, replace or otherwise correct as needed
3.00 POWER DOOR (OPEN)	3.10 No Open Operation (Motor Does Not Run)	3.11 See 1.00 3.12 Doors locked 3.13 Door master lock-out switch ON 3.14 Power door motor harness disconnected or damaged 3.15 Power door motor damaged	Unlock doors or use the keyless transmitter or overhead console passenger power sliding door switch Switch master lock-out switch to OFF Correct or contact Braun Product Support Contact Chrysler Service Center
	3.20 Motor Runs But Door Does Not Move	3.21 Misaligned or otherwise damaged drive cable or door track 3.22 Power door motor clutch failure	Correct or contact Braun Product Support Contact Chrysler Service Center
	3.30 Faulty Open Operation	3.31 Obstruction in door path 3.32 Mechanical binding	Remove obstruction Check and correct
	3.40 Door Does Not Open Fully	3.41 Door doesn't catch full open position hold latch 3.42 Power sliding door module (PSDM) needs recalibrated for extended travel 3.43 See 3.30	Correct or contact Braun Product Support Correct or contact Braun Product Support

FUNCTION	SYMPTOM	POSSIBLE CAUSE	REMEDY
4.00 FOLDOUT RAMP DEPLOY	4.10 No Unfold (Deploy) Operation	4.11 See 1.00 and 3.41 4.12 No door full open signal 4.13 Ramp motor harness disconnected or damaged 4.14 Loose, damaged or missing fold arm securement collar/coupling and/or screws 4.15 Ramp Deploy microswitch out of adjustment or damaged 4.16 Ramp motor damaged 4.17 Ramp electrical override switch damaged or disconnected	Correct or contact Braun Product Support Connect, repair or replace Tighten, replace or otherwise correct as needed Check connection, adjust or replace. Replace motor Check connection or replace.
	4.20 Ramp Contacts Door	4.21 Door not fully open 4.22 See 3.41	Correct or contact Braun Product Support
	4.30 Faulty Unfold (Deploy) Operation	4.31 Ramp Deploy microswitch harness disconnected or damaged 4.32 Misalignment or damage to: <ul style="list-style-type: none"> • Ramp fold bearing • Ramp fold arm • Ramp fold arm bearing slot • Ramp pivot points or hinge(s) 4.33 Mechanical binding 4.34 See 3.41 and 4.15 4.35 Obstruction detected resulting in excessive motor current	Connect, repair or replace Realign, tighten, replace damaged parts or otherwise correct as needed Check and correct Press main electronic controller reset button and try again. If no operation - contact Braun Product Support.
	4.40 Faulty Ramp Extension Unfold (Deploy)	4.41 Ramp extension chain broken, detached, misaligned or otherwise damaged 4.42 Lack of lubrication 4.43 Ramp hinge damage 4.44 See 4.35	Replace, attach, realign or otherwise correct Lubricate - See Maintenance and Lubrication Schedule Correct or replace as needed
5.00 FOLDOUT RAMP STOW	5.10 No Fold (Stow) Operation	5.11 See 1.00 5.12 Ramp Stow Position microswitch out of adjustment or damaged 5.13 Controller doesn't receive door close signal 5.14 See 4.13, 4.14, 4.16 and 4.17	Check connection, adjust or replace. Correct or contact Braun Product Support
	5.20 Faulty Fold (Stow) Operation	5.21 Ramp Stow Position microswitch harness disconnected or damaged 5.22 Fold arm support/stop out of adjustment 5.23 See 3.41, 4.13, 4.14, 4.32, 4.33, 4.35, 4.42 and 4.43	Connect, repair or replace Adjust support/stop for more travel

TROUBLESHOOTING

FUNCTION	SYMPTOM	POSSIBLE CAUSE	REMEDY
6.00 POWER DOOR (CLOSE)	6.10 No Close Operation	6.11 See 3.10, 4.12 and 5.12 6.12 Power slide door module (PSDM) did not see stowed signal	Correct or contact Braun Product Support
	6.20 Motor Runs - Door Does Not Move	6.21 See 3.20	
	6.30 Faulty Operation	6.31 See 3.30	
	6.40 Door Does Not Close Fully (Door Kickback)	6.41 See 3.30 6.42 Ramp obstructing door	Adjust ramp Stow Position micro-switch inward (toward cabin area)
	6.50 Door Contacts Ramp When Closing	6.51 Ramp Stow Position microswitch out of adjustment 6.52 See 4.40, 5.12 and 5.20	Adjust Ramp Stow Position micro-switch inward (toward cabin area)
7.00 KNEEL SYSTEM (RAISE)	7.10 No Raise Operation	7.11 See 1.00, 2.12, 2.13, 2.14, 2.15 and 2.17 7.12 Kneel Raised microswitch harness disconnected/damaged or microswitch damaged	Connect/repair harness or replace microswitch
	7.20 Faulty Operation	7.21 See 2.20	
8.00 KNEEL ELECTRICAL OVERRIDE (RAISE)	8.10 No Operation	8.11 See 1.10, 2.13, 2.14, 2.15 and 2.17	
	8.20 Faulty Operation	8.21 See 2.20	
9.00 RAMP ELECTRICAL OVERRIDE (STOW)	9.10 No Operation	9.11 See 1.10, 4.13, 4.14 and 4.16	
	9.20 Faulty Operation	9.21 See 4.13, 4.32, 4.33, 4.41, 4.42 and 4.43	

Ramp Microswitch Adjustment

The ramp motor assembly is equipped with two microswitches, the deploy microswitch and stow position microswitch.

The deploy microswitch cuts the ramp motor when the platform reaches a position where the ramp will complete the deploy function by the force of gravity (ramp to ground level).

The stow position microswitch determines the full stow position (how far the ramp stows inside the vehicle).

Remove the ramp motor assembly interior cover to access microswitches (located rear of the passenger slide door). Note: It is not necessary to remove any other interior panels.

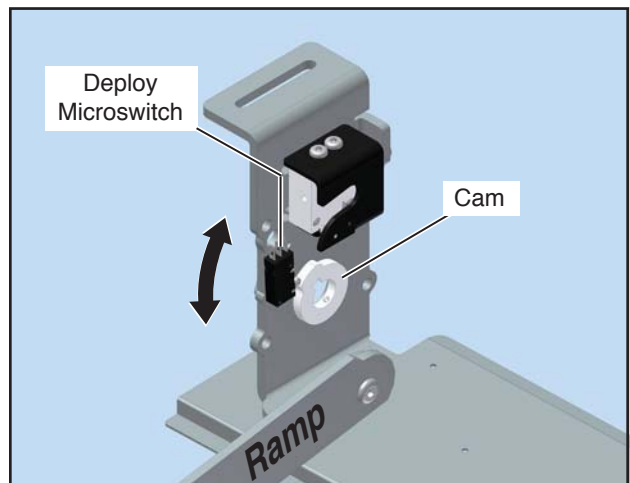
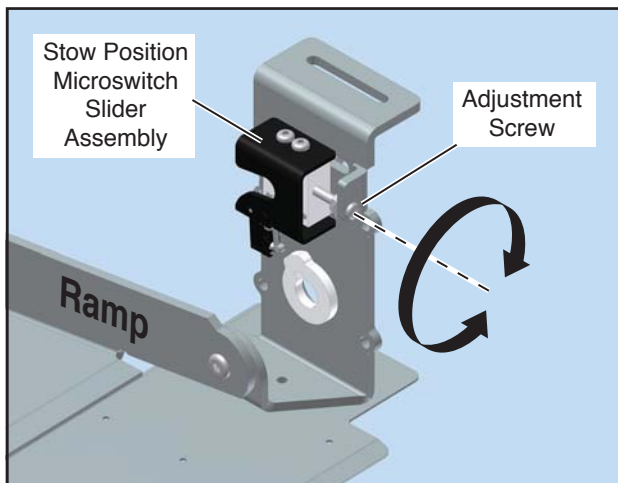

Stow Position Microswitch Adjustment: An adjustment screw moves the position of the stow position slider assembly inward and outward. Turn the screw clockwise to adjust the ramp stowed position inward. Turn the screw counter-clockwise to adjust the ramp position outward. Ensure the ramp does not obstruct the power slide door (check per following procedure).

Door Obstruction: Manually open the slide door fully. Move the top of the ramp out slightly until the ramp enters the path of the door. Press a control switch. **Caution:** Observe and stop door if ramp does not stow fully to avoid damage. If the ramp stows fully and the door closes, the microswitch

is adjusted properly. If the door contacts the ramp, the stow microswitch needs to be adjusted inward. Adjust microswitch slider slightly and repeat procedures.

Deploy Microswitch Adjustment: The deploy microswitch is cam activated. The microswitch is secured with two mounting screws. The microswitch can slide in a rotary motion to change its position in relation to the cam. The deploy microswitch cuts power to the ramp motor, allowing the ramp to gravity down and complete the deploy function. Adjust the switch to allow gravity to complete the deploy operation. Ensure the ramp motor shuts off before the ramp reaches the horizontal position or below.

Kneel Microswitches

The actuator assembly is equipped with two fixed position microswitches (not adjustable). A bracket (vertical tab) at the end of the actuator shaft trips the microswitches as the shaft extends and retracts. If the kneel switches are not activated (tripped), the kneel actuator will clutch (ratchet) continuously for approximately 10 seconds at end of actuator travel.

Kneel Actuator Access: Remove the kneel assembly cover on the vehicle floor under the third row seats. See Switch and Component Location Diagram.

Note: Changing the kneel chain length is prohibited.

BELOW FLOOR OBSTRUCTIONS

2011 Chrysler RT Lowered Floor Minivan (Foldout Ramp) Conversion

When installing an electrical tie-down, power seat or other auxiliary device, obstructions below the floor must be avoided. Obstructions include wiring, fuel system, brake lines, etc. Installers must be aware of these obstructions.

Refer to this illustration when installing aftermarket equipment to avoid contacting or damaging vital components under the floor.

Drilling or cutting into such obstructions may result in potential hazards as well as property damage.

Note: Some wiring harnesses shown may not be present. Avoid all harness locations.

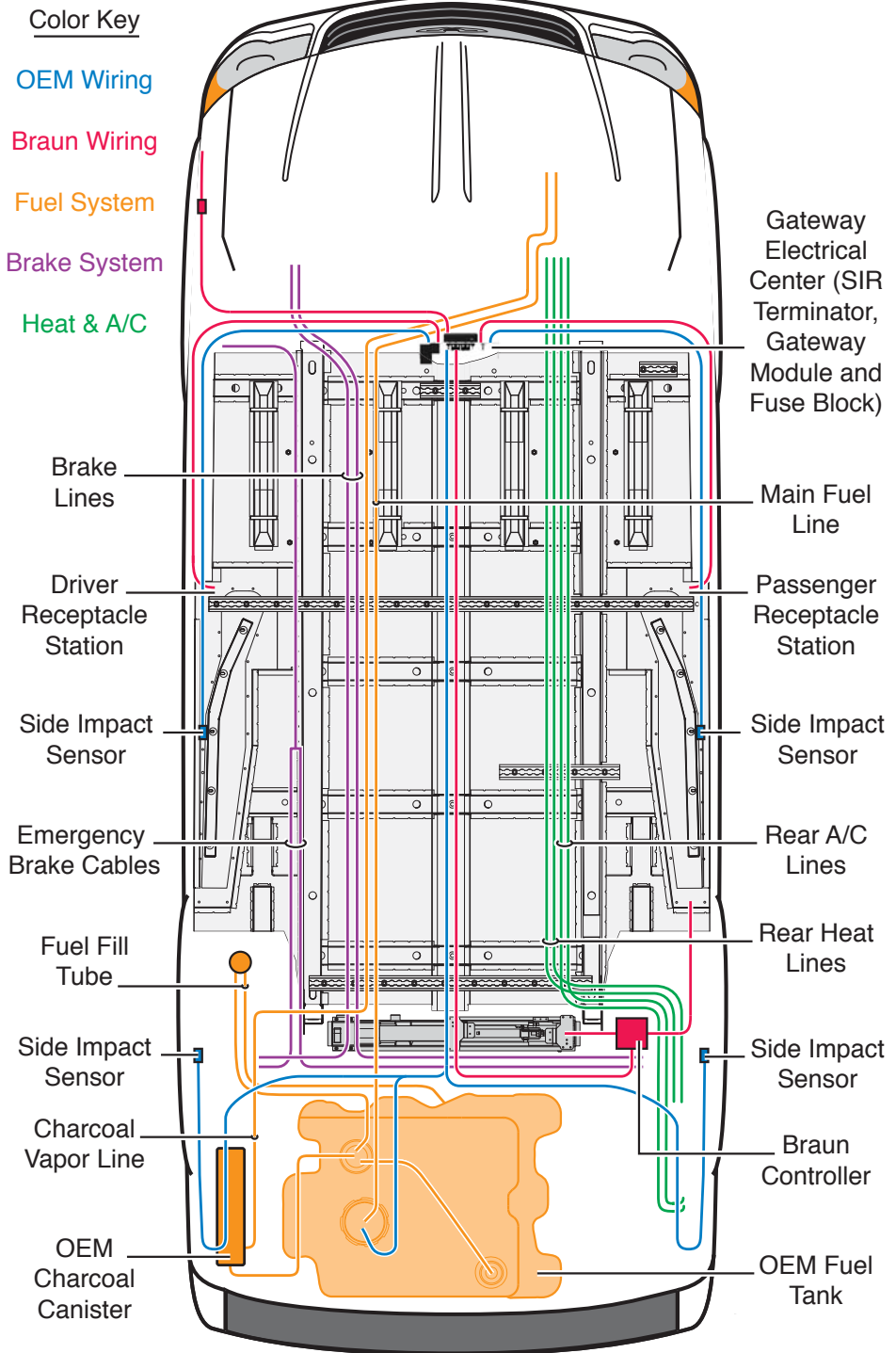

⚠️ WARNING

Check for obstructions such as wires, gas lines, exhaust, etc. before drilling or cutting through floor. Failure to do so may result in serious bodily injury and/or property damage.

⚠ CAUTION

Do not connect auxiliary devices to vehicle battery. Doing so may result in damage to electrical system and/or electronic components.

Auxiliary Power Supply: Do not connect auxiliary devices directly to the vehicle battery. Doing so may result in damage to electrical system and/or electronic components.

Two fuse blocks are provided as an auxiliary power source for dealer-installed auxiliary electrical device(s). Fuse block details and specifications are provided below. The fuse blocks are located in the bottom of the center dash console.

Below Floor Obstructions:

When installing aftermarket equipment, obstructions below the floor must be avoided. Obstructions include wiring, fuel system, brake lines, etc. Installers must be aware of these obstructions.

Refer to the illustration on previous page to avoid contacting or damaging vital components under the floor.

⚠ WARNING



Risk of electrical fire! Install and electrically terminate auxiliary electrical device as specified by device manufacturer.

Fuse Blocks: Two fuse blocks are provided for use as an auxiliary power source (one ignition fuse block and one battery fuse block).

The battery fuse block provides power at all times (independent of the vehicle ignition). The ignition fuse block supplies power only when the vehicle ignition is on.

The installer is responsible for supplying the correct gauge wire and fuse for the particular device to be attached to the fuse block (as specified by the manufacturer of the device).

Ignition Fuse Block: The total maximum load must not exceed 30 amperes.

Battery Fuse Block: The total maximum load must not exceed 40 amperes.

Note: If installing an auxiliary electrical device that requires a power source that exceeds the specified maximum loads, an alternative power source must be provided.

Fuse Block Access: The fuse blocks are located at the bottom of the center console. Remove upper console panel (2 fasteners per side).

Note: The fuse blocks are part of the center console electrical assembly. Two grounding studs are available.

Under Dash Fuse Blocks

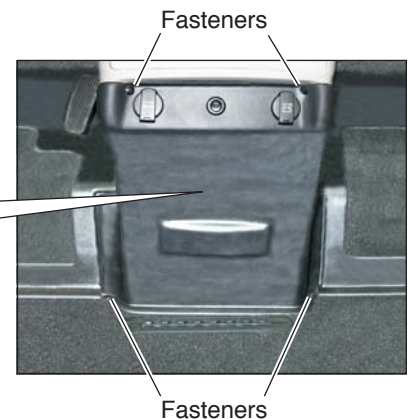
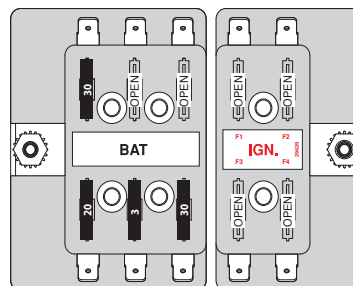

ELECTRONIC CONTROL MODULES

Diagram - Electronic Control Module Connections / Inputs / Indicators

The control module assembly is mounted to the bottom of the passenger side third row seat. Removal of this seat is prohibited. Tip the seat forward to access the module assembly.

Computer Port - Laptop diagnostic connection port to the electronic controller.

Grounding Studs - The controller assembly provides two grounding studs.

Indicator LEDs - LED's illuminate whenever a switch is grounded (as labeled).

Kneel Override - Buttons drive the kneel system in the direction indicated. The kneel LED will illuminate Red when kneeling and Green when unkneeling (raising).

Reset Button - Resets controller.

Speaker Enable - Turns the internal speaker On and Off. The speaker sounds a tone whenever an operate signal is seen (any con-

trol switch is activated). A tone will also sound if the ramp motor pulls current over the controller preset baseline current.

Ramp Select Switch - Sets controller functions to an infloor or foldout ramp.

Ramp Override - Buttons drive the ramp in the direction indicated. The ramp LED will illuminate Red when deploying and Green when stowing.

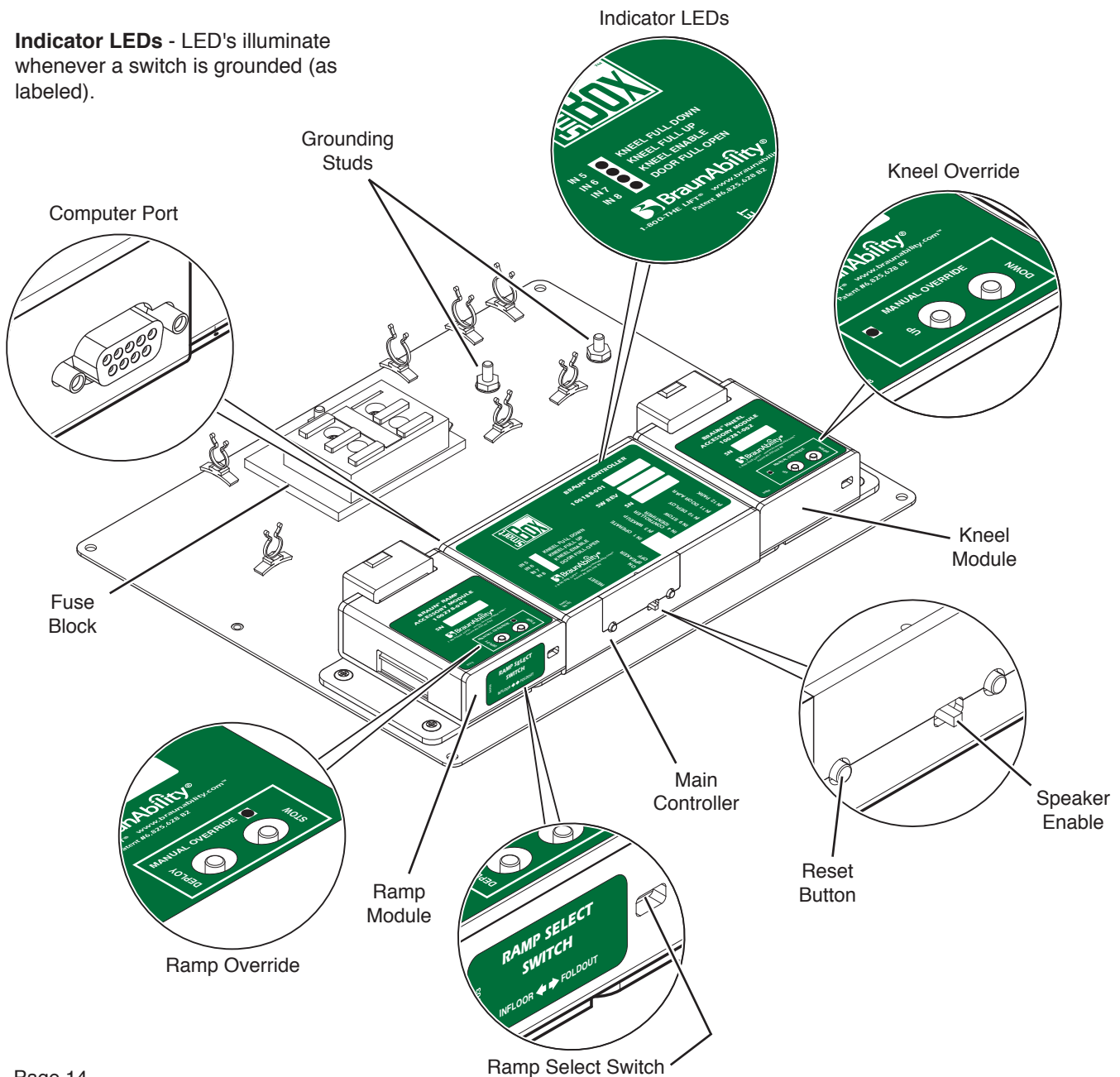

2011 Chrysler RT Conversion (Foldout Ramp) Switch and Component Location Diagram

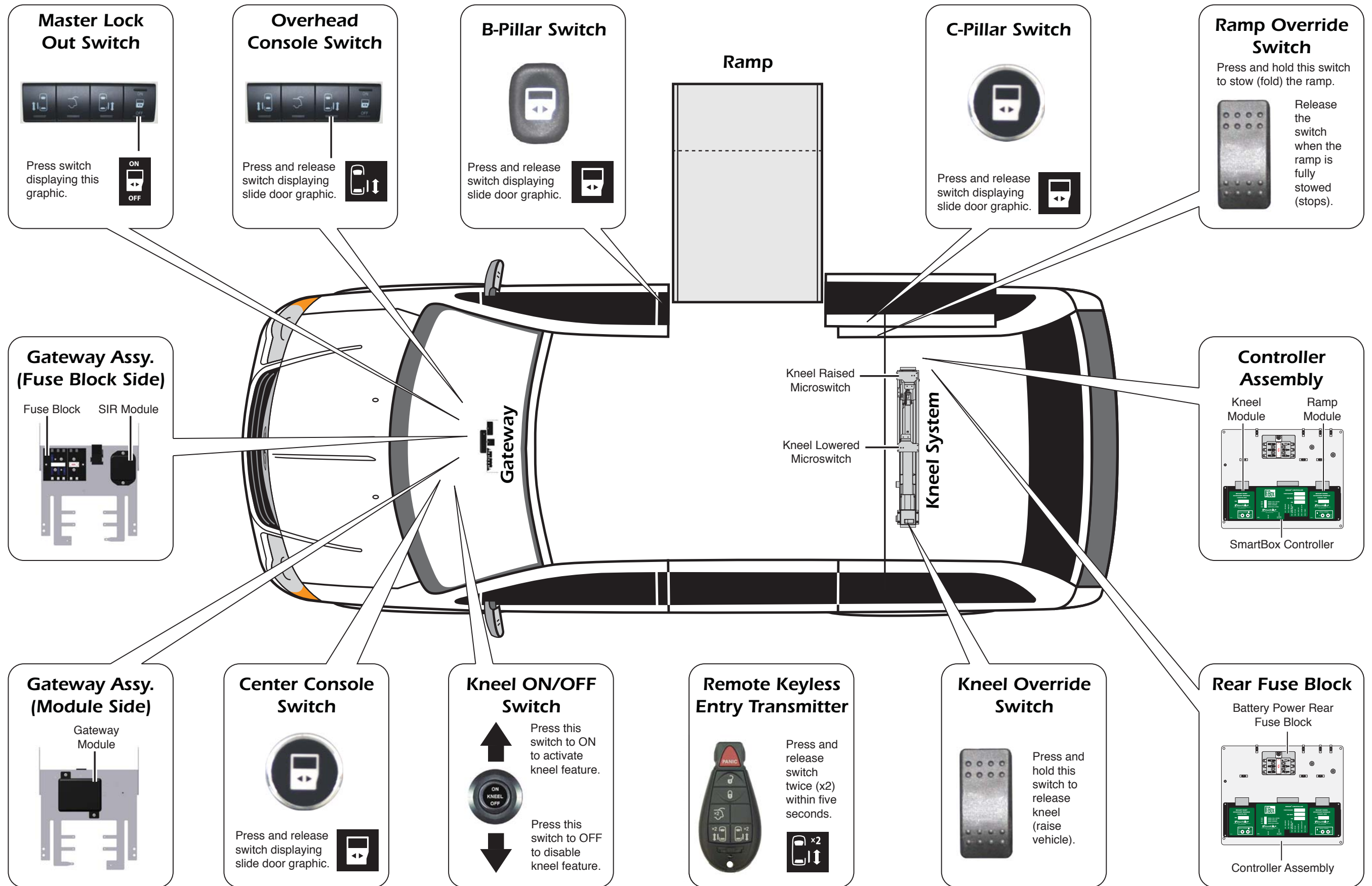

Unfold for:
2011 Foldout
Switch & Component
Location Diagram

Wiring Diagram - 2011 Chrysler RT Conversion (Foldout Ramp) Power Door, Foldout Ramp & Kneel System

14-COND WIRE CODE

PIN	COLOR	FUNCTION
1	OR/BK 14G	Ramp Motor 2
2	WH/BK 20G	Switch Common
3	-	-
4	-	-
5	-	-
6	-	-
7	RD/WH 14G	Battery F1
8	WH/RD/OR 14G	Ramp Motor 1
9	BK 20G	Ramp Deployed
10	WH 20G	Ramp Stowed
11	-	-
12	-	-
13	-	-
14	BK 14G	Ground

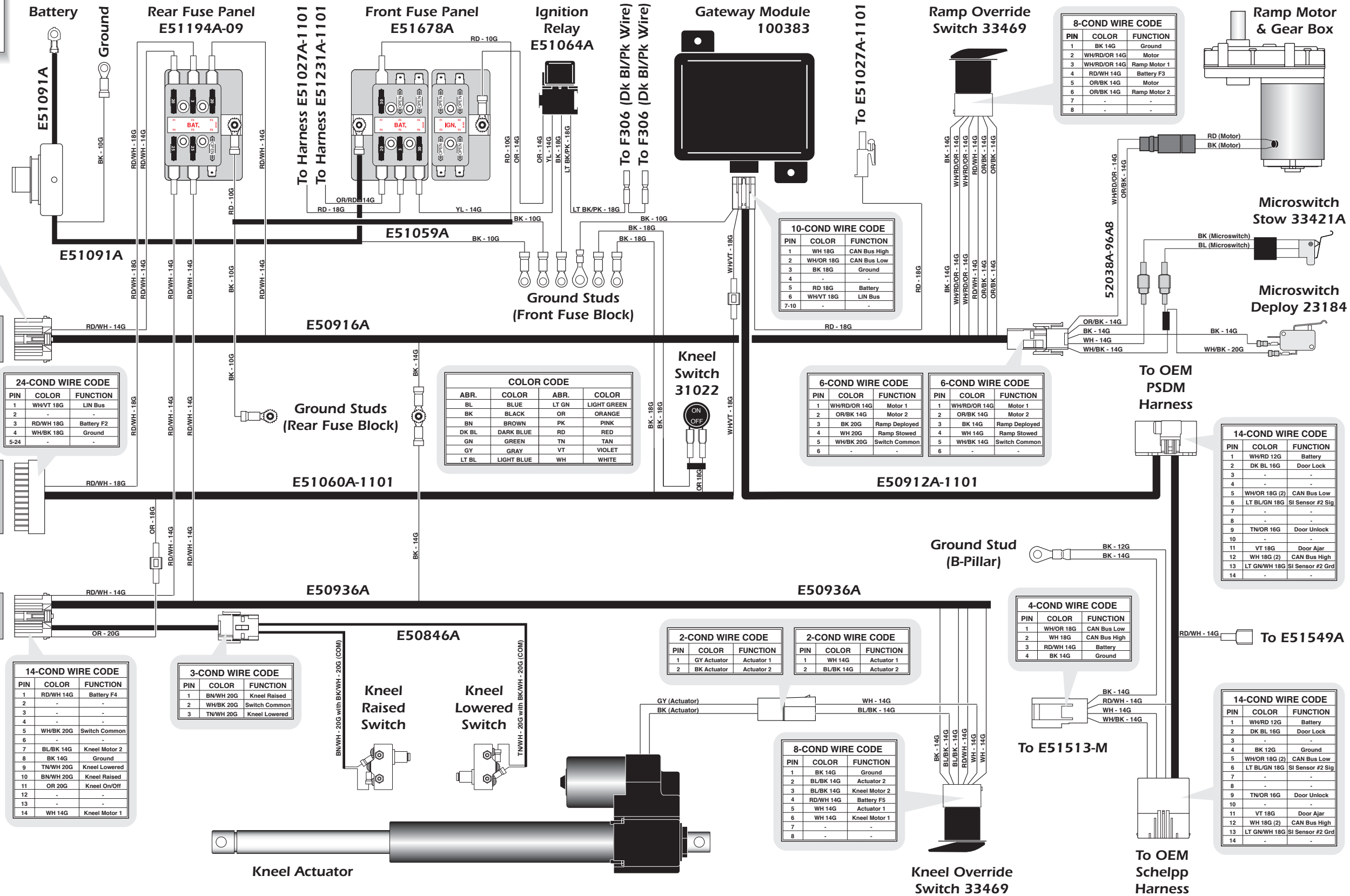

Wiring Diagram - 2011 Chrysler RT Conversion (Foldout Ramp) Front Driver Seat w/o Memory Seat

DRAWING NOTES

Junctions only occur at intersections with junction symbols (⊕).
All other intersections are wire crossings **without** junctions!

All wires are 18 gauge, unless noted.

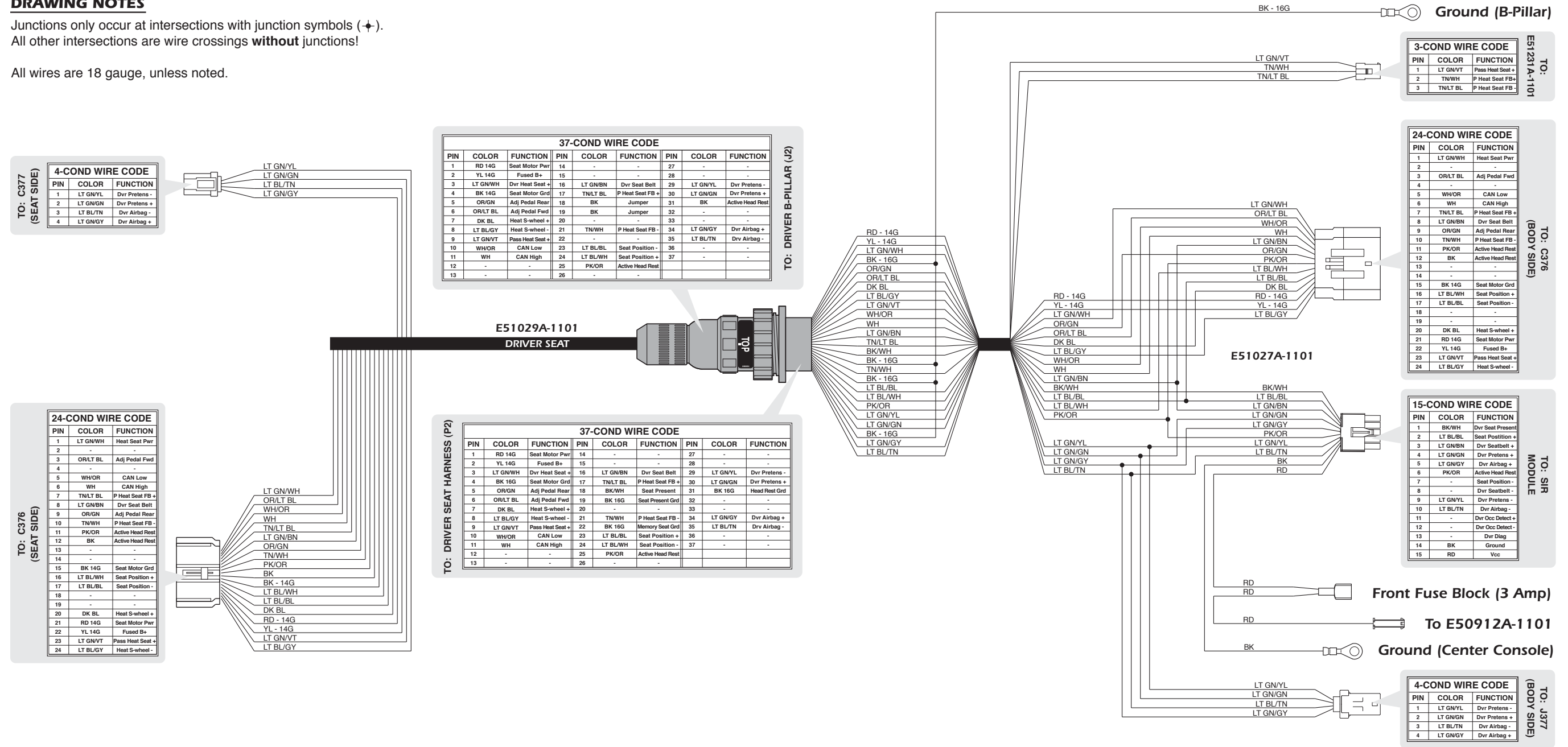

Unfold for:
Wiring Diagram - Front Driver
Seat w/o Memory Seat

Wiring Diagram - 2011 Chrysler RT Conversion (Foldout Ramp) Front Driver Seat with Memory Seat

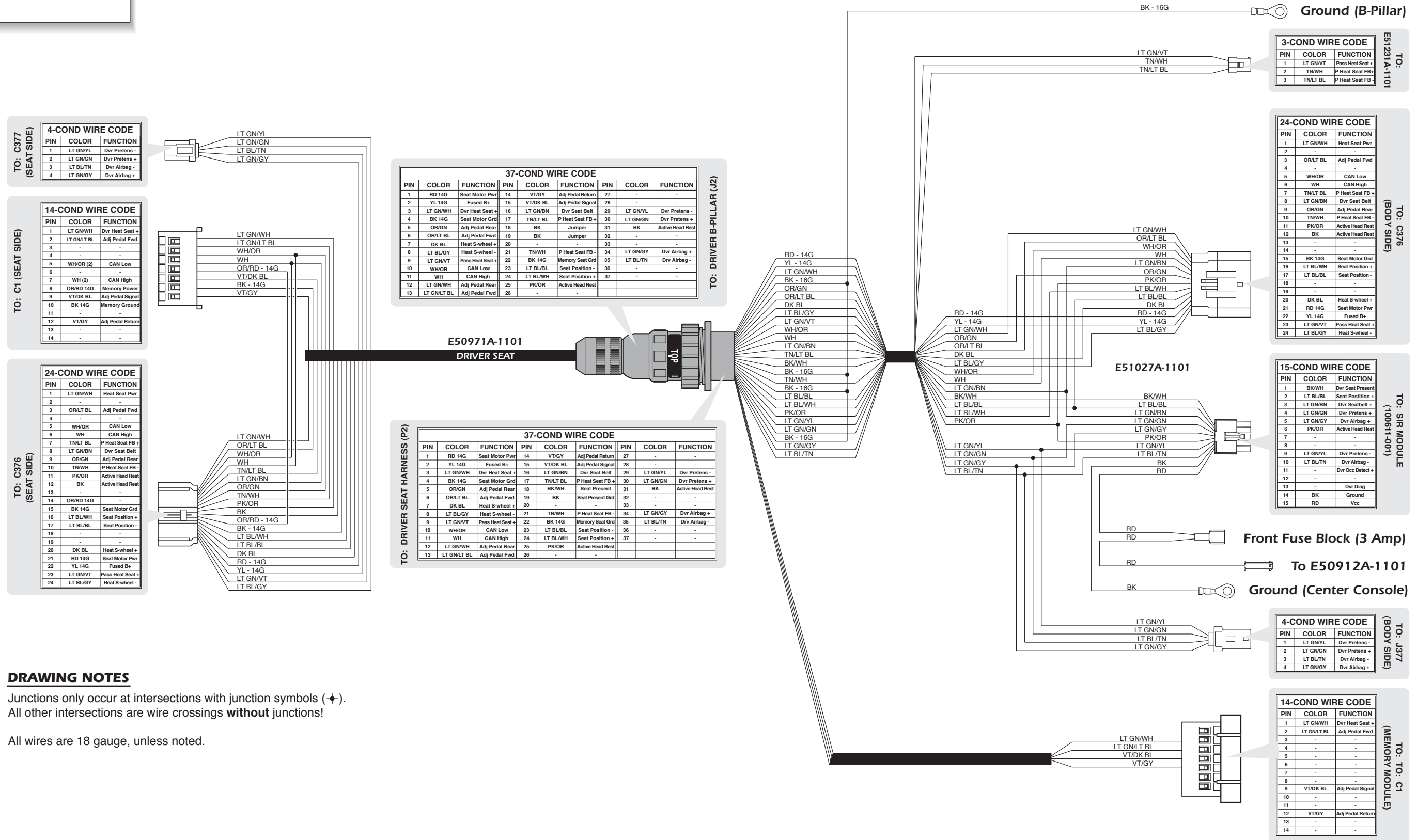

DRAWING NOTES

Junctions only occur at intersections with junction symbols (⊕). All other intersections are wire crossings **without** junctions!

All wires are 18 gauge, unless noted.

Wiring Diagram - 2011 Chrysler RT Conversion (Foldout Ramp) Front Passenger Seat

DRAWING NOTES

Junctions only occur at intersections with junction symbols (⊕).
All other intersections are wire crossings **without** junctions!

All wires are 18 gauge, unless noted.

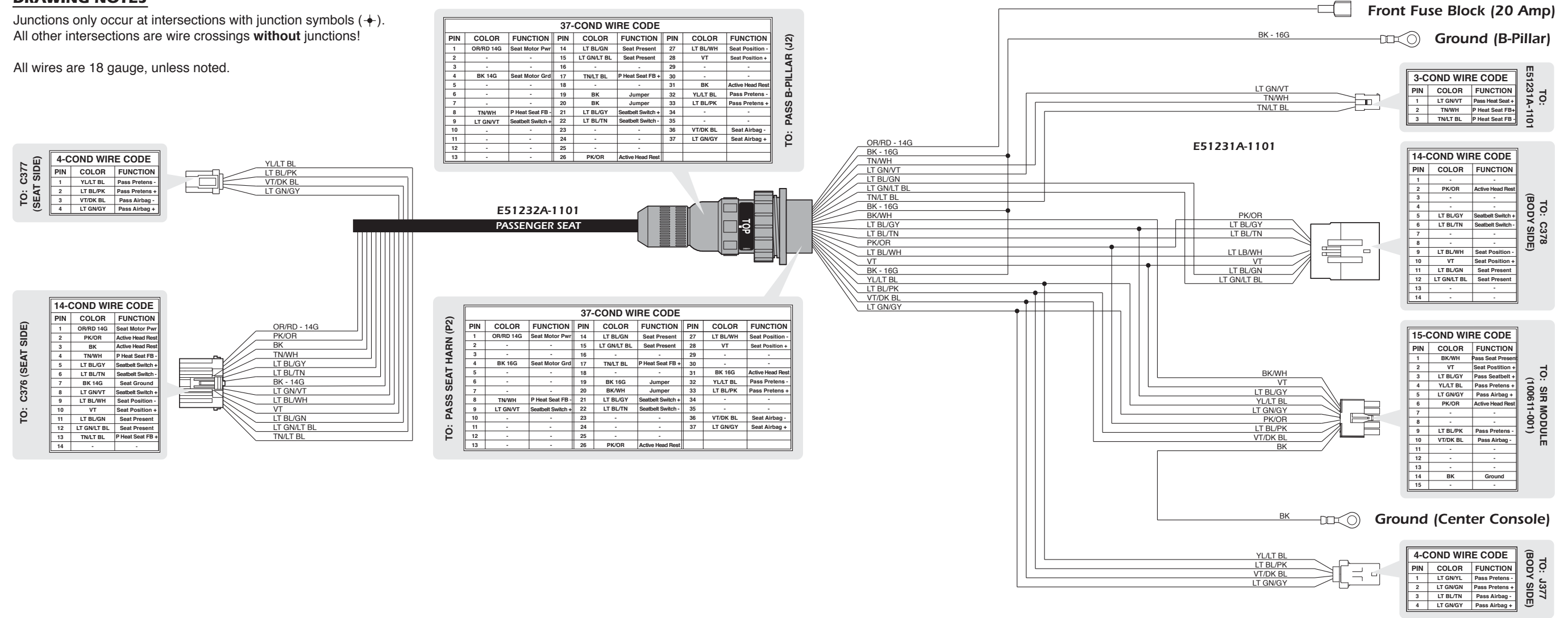

Unfold for:
Wiring Diagram
2011 Foldout
Front Passenger Seat

Exploded View - 2011 Chrysler RT Conversion (Foldout Ramp) Platform Assembly

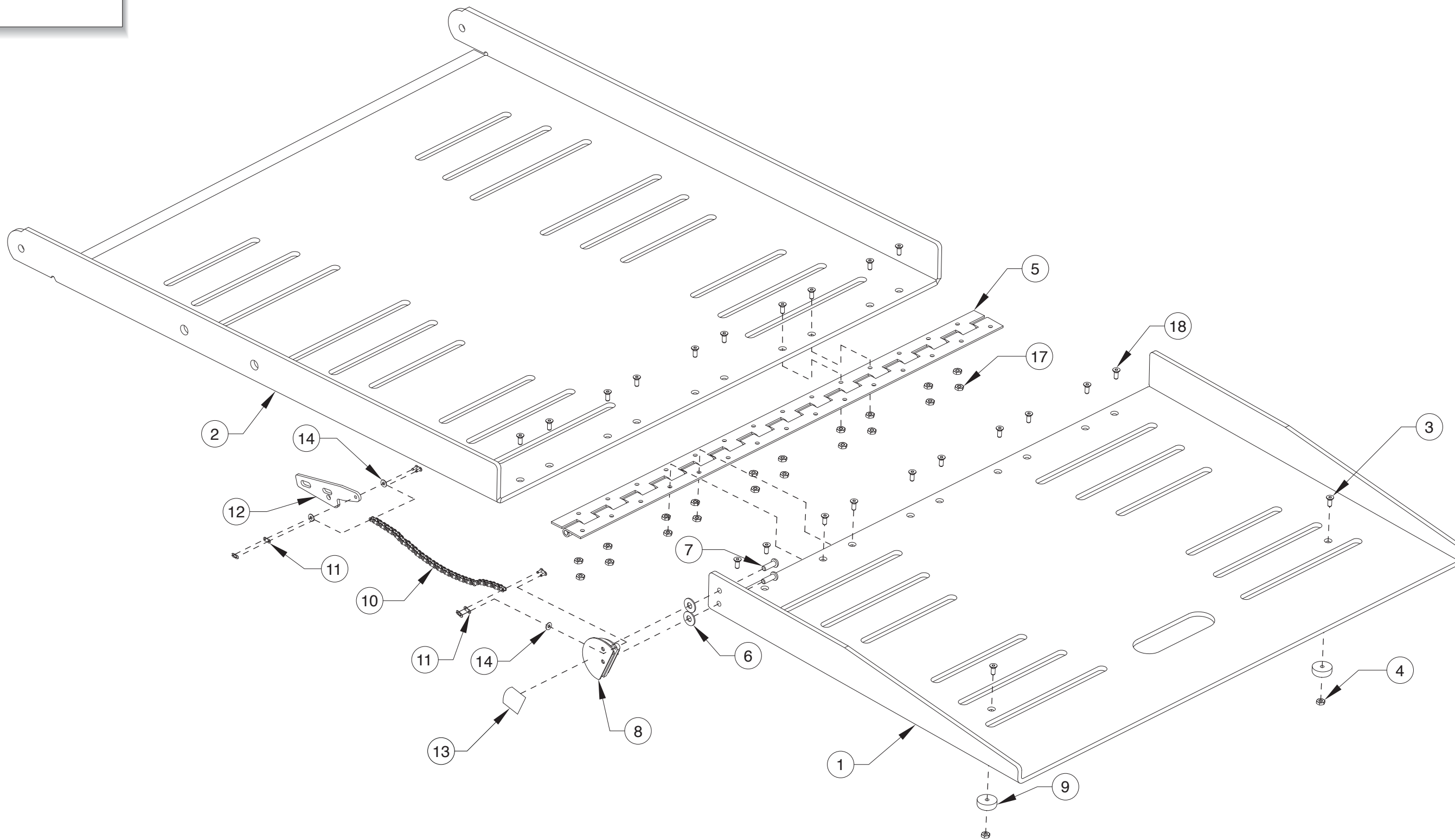

REPLACEMENT PARTS

2011 Chrysler RT Conversion (Foldout Ramp) Platform Assembly

Item	Qty.	Description	Part Number
1	1	RAMP-EXTENSION/29.25" AUTO/2008 CHRYSLER	E50262??-08
2	1	RAMP-BASE/29.25" AUTO/08RT	E51095??
3	2	SCREW-#10-32X1/2 FHDHXS-AUTO BLK-W/PATCH	17192P
4	2	NUT-#10-32 W/LOCKWASHER/AUTO-BK	18349
5	1	HINGE WMT.-S.S. 2" X 1/4" X 29"	18619W029
6	2	WASHER-1/4" FLAT/AUTO-BK	10062
7	2	BOLT-1/4-20X3/4" BHCS NYLK/BKZN	25371
8	1	CAM-CAST RAMP	34317
9	2	BUMPER-RUBBER RECES.31/32 OD	10950
10	1	CHAIN-NICKEL PLATED #35 ROLLER X 9.38"	84314R009.38
11	2	LINK-CHAIN #35	12454
12	1	BRACKET-CABLE TENSIONER/OUTER/BLACK	52568-2908BK
13	1	DECAL-WARN CHAIN HAZ RAMP EVII	26134
14	3	#6 NYLON WASHER	82070-000
15 *	0.001	LOCTITE-BLUE/#242 GEN PURPOSE	18822
16 *	1	SHRINK TUBING-1/2" x 7" LONG	14374R007
17	20	NUT-10-32 HEX CENTER LOCK/AUTO-BK	34290BK
18	20	SCREW-#10-32 X 5/8" FHSC-AUTO BLK-PATCHED	32954P

* Item not shown

REPLACEMENT PARTS

2011 Chrysler RT Conversion (Foldout Ramp) Ramp Assembly Gear, Motor and Base Assembly

Item	Qty.	Description	Part Number
1	1	WMT-MAIN RAMP HOUSING	E51096W??
2	1	MOTOR-RAMP ASSY/KLAUBER 12V. 1.2 RPM	51654AK2907
3	1	WMT-ARM-DRIVES RAMP-GEAR MTR	E40268W-07BK
4*	1	SUPPORT-GEAR MOTOR/FOLDING RAMP/08RT	E51179BK
5	1	STOW SWITCH SLIDER	E40481
6	4	NUT-SHOULDER 3/4" HEX/0.27 H	32385
7	2	WASHER-NYLON 1/4IDX11/16X.030	12690
8	1	BOLT-1/4-20 X 3" ZN FT/AUTO-BK	23976
9	1	NUT-1/4-20 HEX LOCK/AUTO-BK	10775
10	1	COLLAR-SPLIT-3/4" SHAFT/RMP MTR/INNER/BK	52565-2905BK
11	4	SCREW-1/4-20 X 1" SOC HD CAP	24221
12	1	CAM-MICRO-SWITCH ADJUST-EV	52573-2905
13	1	SCREW-#10-32 X 5/16" SET/AUTO-BK	11562
14	4	SCREW-5/16-18 X 7/8 BUTTON HD W/PATCH	81022
15	1	PLATE-TAPPED #4-40 MICRO SWITCH	24998
16	1	MICRO SWITCH-FLR LVL/CUPPED	34806
17	2	SCREW-#4-40 X 3/4" RD. HD./AUTO-BK	11483
18	4	BOLT-1/4-20 X 1/2 BUT HD SOC/AUTO-BK	15733
19	1	ASSEMBLY-FOLDING RAMP STOW SWITCH	33421A
20	1	NUT-#4-40 w/LOCKWASHER/AUTO-BK	19537
21	1	PIN-RAMP SUPPORT-96SC 29" RAMP	51815-2905
22	1	LATCH BOLT-SUPPORT-29" RAMP	51541-2905
23	4	WASHER-5/16" LOCK/AUTO-BK	10068
24 *	0.001	LOCTITE-BLUE/#242 GEN PURPOSE	18822
25	1	BOLT-1/4-20X3/4" BHCS NYLK/BKZN	25371
26	2	WASHER-1/4" FLAT/AUTO-BK	10062
27	1	RAMP DEPLY SWITCH ARMATURE GUIDE	34846

* Item not shown

Exploded View - 2011 Chrysler RT Conversion (Foldout Ramp) Ramp Assembly Gear, Motor and Base Assembly

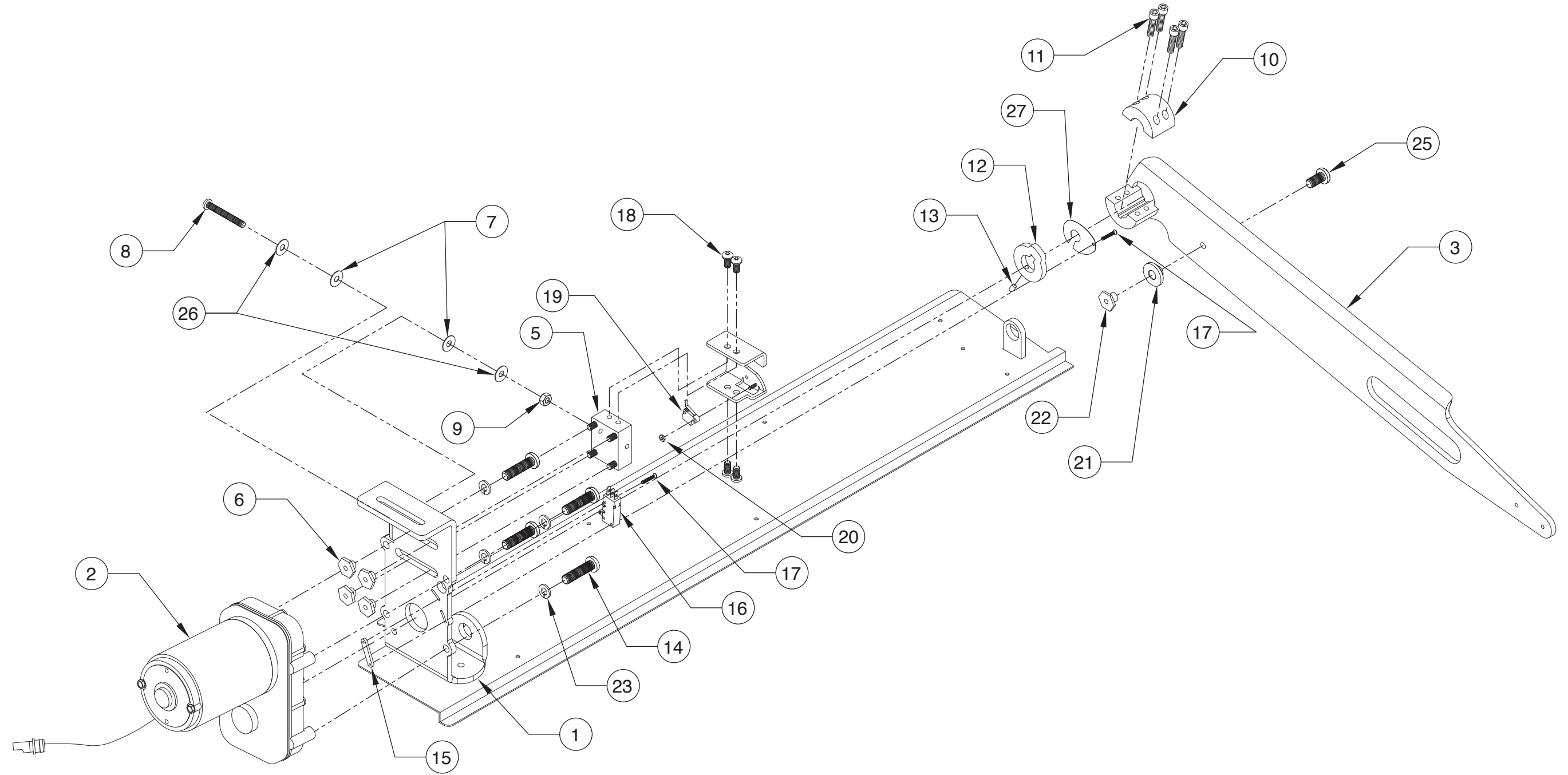

REPLACEMENT PARTS

2011 Chrysler RT Conversion (Foldout Ramp) Ramp Assembly

Item	Qty.	Description	Part Number
1	1	RAMP ASSY-BASE & EXT/29.25" AUTO	E51095??A2909
2	1	ASSY-MAIN RAMP HOUSING	E51096A??
3	2	BEARING-FLANGE-5/8" X 1/4"-10FDU04	28435
4	2	SCREW-1/4-20 X 3/8" FLBHSCS-	28252
5	3	BOLT-3/8-16 X 3/4" FLBHSCS-GD8	25171
6	2	PIVOT PIN/BUSHING/EV RAMP/2905	52571-2905
7*	1	HARNESS-RAMP EXT./CONTROLLER-OAKTEC	52038A-96A8
8*	0.001	LOCTITE-BLUE/#242 GEN PURPOSE	18822
9	1	RETAINER-BEARING	21451-03
10	1	BEARING-1/2ID X 1 1/8 OD-BALL	21371
11	1	WASHER-.519ID X .876OD X .074	12621
12	2	WASHER-.63 X .8 X .06 NYLON{10	83584
13	1	WASHER-UHMW 1.500 OD X .76 ID X 0.062	29680
14	2	WASHER-1/4" EXT STAR TOOTH LOCK ZP	83588

* Item not shown

REPLACEMENT PARTS

2011 Chrysler RT Conversion (Foldout Ramp) Kneel Assembly

Item	Qty.	Description	Part Number
1	1	ASSY-KNEEL BOX/ACTUATOR/RT	E51016A
2	1	KNEEL SWITCH BRACKET	E50859BK
3	1	KNEEL SWITCH BRACKET-TOP	E50880BK
4	1	SWITCH-DPDT VFD1	33469
5	4	BOLT-1/4-20 X 3/4 GR5-HEX/AUTO-BK	10970
6	1	ASSY-ACT/K2xG20-12V-08/2000#/8"STROKE	33440ART
7	1	BKT-KNEEL-FULL OUT DVR	E50888D
8	1	BKT-KNEEL-FULL OUT PASS	E50888P
9	2	SWITCH-LIMIT/PLUNGER STYLE/WEATHER-PROOF	31784WP
10	4	SCREW-#8-32 X 1"-MCH TRUSS HD/AUTO-BK	19912BK

REPLACEMENT PARTS

Exploded View - 2011 Chrysler RT Conversion (Foldout Ramp) Kneel Assembly

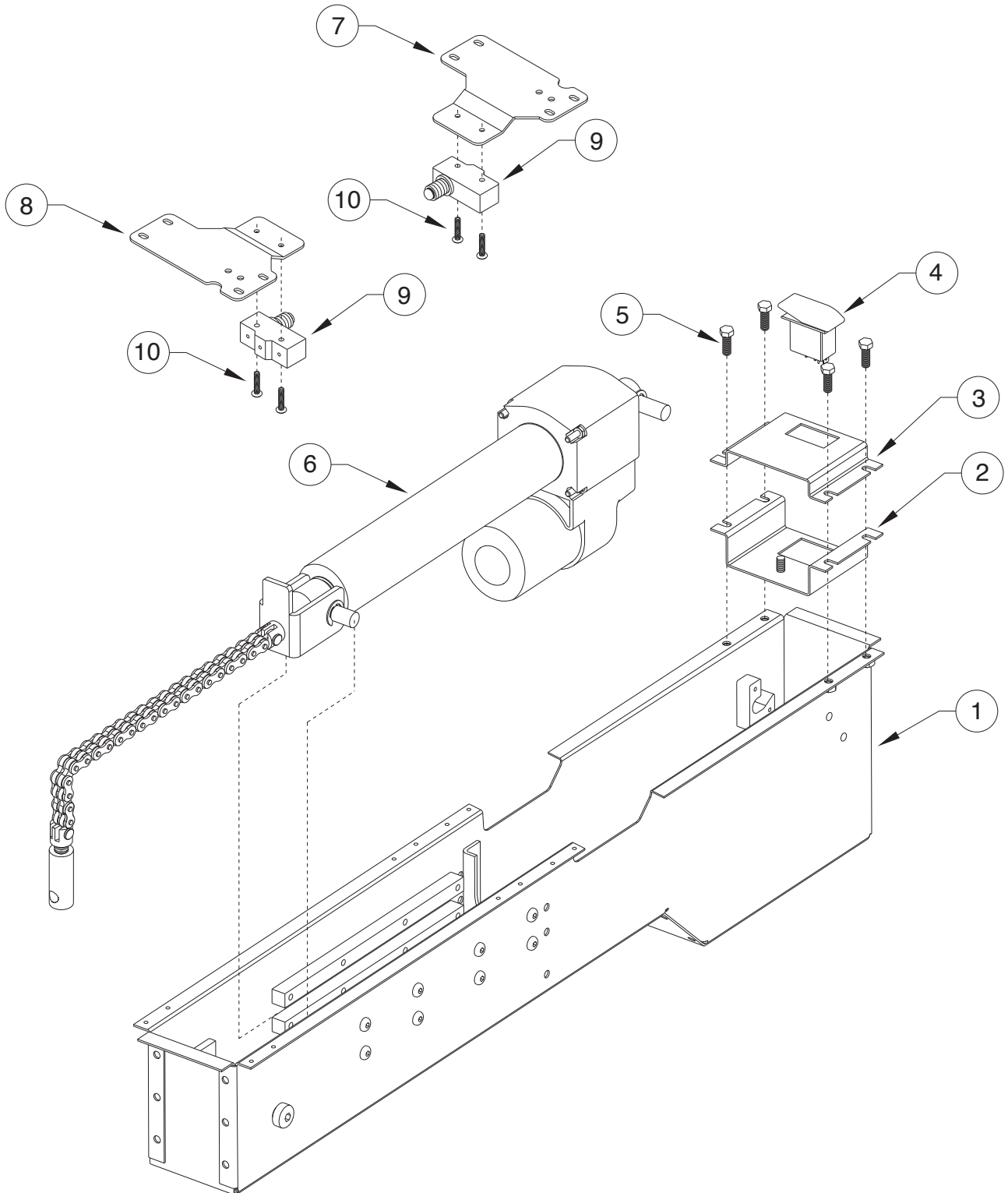

DIMENSIONS

Dimensions - 2011 Chrysler RT Conversion (Foldout Ramp)

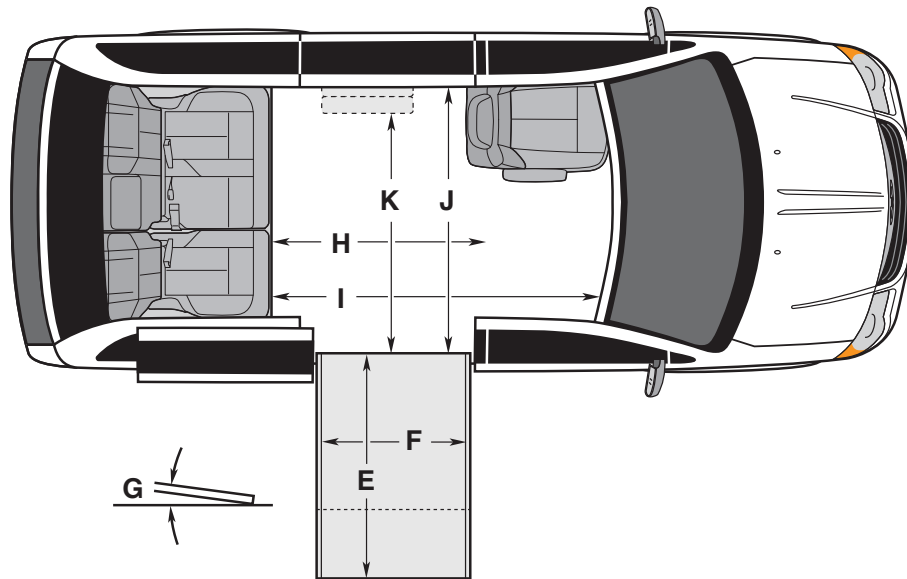
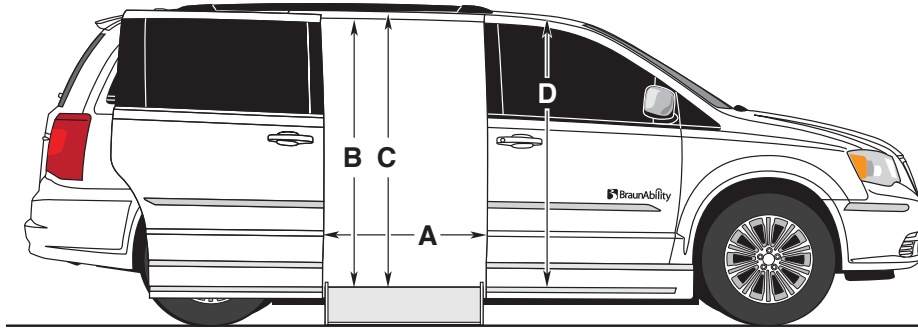

All dimensions are for reference only.

Foldout Ramp

Door Opening Usable Width (Slide Door)	A	31-1/2"
Door Opening Usable Height (Slide Door)	B	52-1/2"
Interior Height at Center of Van	C	57-1/4"
Interior Height at Driver and Passenger Position	D	56-1/4"
Ramp Length	E	52"
Ramp Width (Usable Clear Opening)	F	29-1/4"
Ramp Angle (with Vehicle Kneeled)	G	9.2°
Interior Floor Length (Behind Front Seats)	H	57"
Overall Interior Floor Length (Flat Area)	I	87-1/2"
Interior Width at B Pillars	J	62"
Interior Width to Optional One Passenger Flip & Fold Seat (Folded)	K	46"

Due to manufacturing tolerances both with the OEM vehicle and the conversion components, all dimensions may vary slightly from those shown.

"Providing Access to the World"®



**Over 300 Braun
Dealers Worldwide**

 **THE BRAUN
CORPORATION**
"Providing Access to the World"



International Corporate Hdqrs: P.O. Box 310 Winamac, IN 46996 USA
1-800-THE LIFT® (574) 946-6153 FAX: (574) 946-4670



Because Life is a Moving Experience®

36745
August 2011

Patent #6,825,628
Patent #7,798,761
Patent #7,551,995



International Corporate Hdqrs: P.O. Box 310 Winamac, IN 46996 USA
1-800-THE LIFT® (574) 946-6153 FAX: (574) 946-4670
braunmobility.com™ entervan.com™

All illustrations, descriptions and specifications in this manual are based on the latest product information available at the time of publication. The Braun Corporation reserves the right to make changes at any time without notice.

**Braun Lowered Floor Conversions
featuring 2011 Chrysler Minivans**